



The New  
**FIGHTER**  
Professional for Professional



**FM65FS**  
Hi-GEAR

240PS | 4x2

Andalan Bisnis Sejati

The New  
**FIGHTER**  
Professional for Professional



MODEL		<b>FM6SFS LITE-GEAR</b>	
Penggerak		4x2	
DIMENSI			
	Satuan		
Jarak Sumbu Roda	mm	4.280	
Panjang Keseluruhan	mm	7.510	
Lebar Keseluruhan	mm	2.425	
Tinggi Keseluruhan	mm	2.695	
Jarak roda depan kiri-kanan	mm	1.928	
Jarak roda belakang kiri-kanan	mm	1.844	
BERAT			
Berat chassis termasuk kabin	kg	5.050	
Depan	kg	2.935	
Belakang	kg	2.115	
Max G.V.W	kg	16.000	
Depan	kg	6.000	
Belakang	kg	10.000	
KEMAMPUAN			
Kecepatan Maksimum	km/jam	86	
Daya tanjak dengan Max G.V.W	%	45	
Radius putar minimum	m	7.3	
MESIN			
Model		6M60	
Tipe		SOHC (Single Over Head Camshaft), 6 Silinder Direct Injection	
Diameter X Langkah	mm	118x115	
Isi Silinder	cc	7.545	
Daya Maksimum	PS/rpm	240/2.600	
Torsi Maksimum	Kgm/rpm	70/1.400	
TRANSMISI			
Model		M8S6	
Tipe		6 gigi maju dan 1 gigi mundur	
Perbandingan gigi		7.814 - 4.506 - 2.690 - 1.621 - 1.000 - 0.894 Mundur 6.849	
Perbandingan gigi akhir		7.166	
Tipe Kopling		Single Dry Clutch	
KEMUDI			
Tipe		Ball nut type with integral type hydraulic power booster, telescopic & tilt steering column with steering lock	
SUSPENSI			
Depan		Laminated leaf springs dengan shock absorbers	
Belakang		Laminated leaf springs	
REM			
Rem kaki (Service brake)		Air over hydraulic dengan sirkuit ganda	
Rem tangan (Parking brake)		Internal expand type pada propeller shaft	
Rem pembantu		Sistem pengereman gas buang (Exhaust brake)	
BAN DAN RODA			
Ban Depan		Tunggal, 10.00-20-16PR	
Ban Belakang		Ganda, 10.00-20-16PR	
SISTEM LISTRIK			
Tegangan	Volt	24	
KAPASITAS			
Tangki	liter	200	
KABIN PENGEMUDI			
		All steel, tilt cab (Kabin Jungkit)	

CATATAN : Untuk peningkatan dan penyesuaian dengan perkembangan teknologi, spesifikasi ini sewaktu - waktu dapat berubah tanpa pemberitahuan terlebih dahulu.

## Performa



**240PS**  
Common Rail  
EURO 3

### MESIN 6M60

Dengan tenaga 240 PS, menggunakan system common rail yang lebih efisien dan ramah lingkungan.

### CHASSIS KUAT

Chassis tebal dan tanpa sambungan, dengan posisi kelingan / rivet disisi samping, sehingga meningkatkan daya tahan chassis dan mempermudah dalam pemasangan Rear Body.



## Keamanan & Kenyamanan



### Kabin Modern & Rigid

Dirancang dengan konsep yang modern dan juga menggunakan Rigid Kabin sehingga selain terlihat modern tetapi juga mengutamakan sisi keamanan bagi penggunanya.

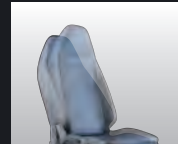

### Kenyamanan Berkendara

Ruang Kabin Luas dengan air suspension pada kursi pengemudi. Posisi Jok dapat diatur tinggi, jarak dan kemiringan sudutnya serta kemudi yang juga dapat diatur tinggi dan jaraknya memberikan pilihan posisi kenyamanan berkendara bagi pengemudi.

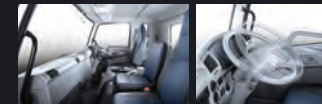

## Fitur Pelengkap



### Front Panel

Front Panel depan untuk memudahkan pemeriksaan harian.



### Kabin Jungkit

Kabin Jungkit dengan sudut bukaan yang lebar (67°).



### Cornering Lamp

Tambahan Cornering Lamp untuk meningkatkan keamanan saat berbelok.



### Job order planning

Perencanaan Kerja (Driver, Vehicle, Routes & Area)



### Driver management

Pengaturan Penugasan Pengemudi



### Vehicle management

Pengaturan Penggunaan & Perawatan Kendaraan



### Real time monitoring

Mengetahui Lokasi, Situasi & Status Perjalanan Kendaraan



### Report / Evaluation

Laporan & Analisa Terkait Pengoperasian Kendaraan



## Dimensi Kendaraan

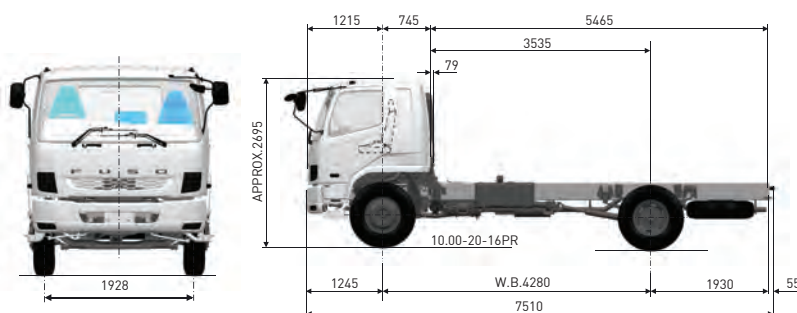

Manufactured at PT Krama Yudha Ratu Motor, Jakarta- Indonesia

MITSUBISHI FUSO authorized distributor



PT Krama Yudha Tiga Berlian Motors  
www.ktbefuso.co.id



MITSUBISHI FUSO TRUCK & BUS CORPORATION  
www.mitsubishi-fuso.com